





# Table of Contents

Intended Use .....	2
Important .....	2
Warnings .....	2
Cautions .....	3
Contraindications .....	3
Symbol Key .....	4
System Contents .....	5
System Overview .....	5
Control Buttons .....	6
Available Therapies .....	6
Installing the Air Filters .....	6
Connecting the Breathing Circuit .....	7
Where to Place the Device .....	7
Supplying AC Power to the Device .....	7
Display .....	8
Starting the Device .....	9
Ramp Feature .....	9
Humidifier Preheat .....	9
Navigating the Patient Settings .....	10
Device Messages .....	12
Enhanced Compliance Check .....	12
Troubleshooting .....	13
Accessories .....	15
Traveling with the System .....	16
Cleaning the Device .....	16
Cleaning or Replacing the Filters .....	16
Cleaning the Tubing .....	16
Service .....	16
Specifications .....	17
Disposal .....	18
How to Contact Philips Respironics .....	18
EMC Information .....	19
Limited Warranty .....	Back Page

**CAUTION:** U. S. federal law restricts this device to sale by or on the order of a physician.

## Intended Use

The Philips Respironics REMstar SE system delivers positive airway pressure therapy for the treatment of Obstructive Sleep Apnea in spontaneously breathing patients weighing over 30kg (66 lbs). It is for use in the home or hospital/institutional environment.

## Important

The device is to be used only on the instruction of a licensed physician. Your home care provider will make the correct pressure settings according to your health care professional's prescription.

Several accessories are available to make your OSA treatment with the REMstar SE system as convenient and comfortable as possible. To ensure that you receive the safe, effective therapy prescribed for you, use only Philips Respironics accessories.

## Warnings

*A warning indicates the possibility of injury to the user or the operator.*

- This manual serves as a reference. The instructions in this manual are not intended to supersede the health care professional's instructions regarding the use of the device.
- The operator should read and understand this entire manual before using the device.
- This device is not intended for life support.
- The device should be used only with masks and connectors recommended by Philips Respironics or with those recommended by the health care professional or respiratory therapist. A mask should not be used unless the device is turned on and operating properly. The exhalation port(s) associated with the mask should never be blocked. **Explanation of the Warning:** The device is intended to be used with special masks or connectors that have exhalation ports to allow continuous flow of air out of the mask. When the device is turned on and functioning properly, new air from the device flushes the exhaled air out through the mask exhalation port. However, when the device is not operating, enough fresh air will not be provided through the mask, and exhaled air may be rebreathed. Rebreathing of exhaled air for longer than several minutes can in some circumstances lead to suffocation.
- If you are using a full face mask (a mask covering both your mouth and your nose), the mask must be equipped with a safety (entrainment) valve.
- When using oxygen with this system, the oxygen supply must comply with local regulations for medical oxygen.
- Oxygen supports combustion. Oxygen should not be used while smoking or in the presence of an open flame.
- When using oxygen with this system, turn the device on before turning on the oxygen. Turn the oxygen off before turning the device off. This will prevent oxygen accumulation in the device. **Explanation of the Warning:** When the device is not in operation and the oxygen flow is left on, oxygen delivered into the tubing may accumulate within the device's enclosure. Oxygen accumulated in the device enclosure will create a risk of fire.
- When using oxygen with this system, a Philips Respironics Pressure Valve must be placed in-line with the patient circuit between the device and the oxygen source. The pressure valve helps prevent the backflow of oxygen from the patient circuit into the device when the unit is off. Failure to use the pressure valve could result in a fire hazard.
- Do not connect the device to an unregulated or high pressure oxygen source.
- Do not use the device in the presence of a flammable anaesthetic mixture in combination with oxygen or air, or in the presence of nitrous oxide.
- Do not use the device near a source of toxic or harmful vapors.
- Do not use this device if the room temperature is warmer than 35° C (95° F). If the device is used at room temperatures warmer than 35° C (95° F), the temperature of the airflow may exceed 43° C (109° F). This could cause irritation or injury to your airway.
- Do not operate the device in direct sunlight or near a heating appliance because these conditions can increase the temperature of the air coming out of the device.
- Contact your health care professional if symptoms of sleep apnea recur.
- If you notice any unexplained changes in the performance of this device, if it is making unusual or harsh sounds, if it has been dropped or mishandled, if water is spilled into the enclosure, or if the enclosure is broken, disconnect the power cord and discontinue use. Contact your home care provider.
- Repairs and adjustments must be performed by Philips Respironics-authorized service personnel only. Unauthorized service could cause injury, invalidate the warranty, or result in costly damage.
- Periodically inspect electrical cords and cables for damage or signs of wear. Discontinue use and replace if damaged.
- To avoid electrical shock, always unplug the power cord from the wall outlet before cleaning the device. **DO NOT** immerse the device in any fluids.
- If the device is used by multiple persons (such as rental devices), a low-resistance, main flow bacteria filter should be installed in-line between the device and the circuit tubing to prevent contamination.

- Be sure to route the power cord to the outlet in a way that will prevent the cord from being tripped over or interfered with by chairs or other furniture.
- Using this device at an incorrect altitude setting could result in airflow pressures higher or lower than the prescribed setting. Always verify the altitude setting when travelling or relocating, and adjust the system accordingly.
- This device is activated when the power cord is connected.
- For safe operation when using a humidifier, the humidifier must always be positioned below the breathing circuit connection at the mask and the air outlet on the device. The humidifier must be level for proper operation.

**Note:** Please see the “Limited Warranty” section of this manual for information on warranty coverage.

## Cautions

*A Caution indicates the possibility of damage to the device.*

- Medical electrical equipment needs special precautions regarding EMC and needs to be installed according to EMC information. Contact your home care provider regarding EMC installation information.
- Mobile RF communications equipment can affect medical electrical equipment.
- Pins of connectors marked with the ESD warning symbol shall not be touched and connections shall not be made without special precautions. Precautionary procedures include methods to prevent build-up of electrostatic charge (e.g., air conditioning, humidification, conductive floor coverings, non-synthetic clothing), discharging one’s body to the frame of the equipment or system or to earth. It is recommended that all individuals that will handle this device understand these precautionary procedures at a minimum as part of their training.
- Before operating the device, ensure that the SD card cover is replaced whenever any of the accessories such as the Link Module or Modem are not installed. Refer to the instructions that came with your accessory.
- Condensation may damage the device. If this device has been exposed to either very hot or very cold temperatures, allow it to adjust to room temperature (operating temperature) before starting therapy. Do not operate the device outside of the operating temperature range shown in the Specifications.
- Do not use extension cords with this device.
- Do not place the device directly onto carpet, fabric, or other flammable materials.
- Do not place the device in or on any container that can collect or hold water.
- A properly installed, undamaged reusable foam inlet filter is required for proper operation.
- Tobacco smoke may cause tar build-up within the device, which may result in the device malfunctioning.
- Dirty inlet filters may cause high operating temperatures that may affect device performance. Regularly examine the inlet filters as needed for integrity and cleanliness.
- Never install a wet filter into the device. You must ensure sufficient drying time for the cleaned filter.
- Always ensure that the DC power cord securely fits into your therapy device prior to use. Contact your home care provider or Philips Respironics to determine if you have the appropriate DC cord for your specific therapy device.
- When DC power is obtained from a vehicle battery, the device should not be used while the vehicle’s engine is running. Damage to the device may occur.
- Only use a Philips Respironics DC Power Cord and Battery Adapter Cable. Use of any other system may cause damage to the device.

## Contraindications













When assessing the relative risks and benefits of using this equipment, the clinician should understand that this device can deliver pressures up to 20 cm H<sub>2</sub>O. In the event of certain fault conditions, a maximum pressure of 30 cm H<sub>2</sub>O is possible. Studies have shown that the following pre-existing conditions may contraindicate the use of CPAP therapy for some patients:

- Bullous Lung Disease
- Pathologically Low Blood Pressure
- Bypassed Upper Airway
- Pneumothorax
- Pneumocephalus has been reported in a patient using nasal Continuous Positive Airway Pressure. Caution should be used when prescribing CPAP for susceptible patients such as those with: cerebral spinal fluid (CSF) leaks, abnormalities of the cribriform plate, prior history of head trauma, and/or pneumocephalus. (Chest 1989; 96:1425-1426)

The use of positive airway pressure therapy may be temporarily contraindicated if you exhibit signs of a sinus or middle ear infection. Not for use with patients whose upper airways are bypassed. Contact your health care professional if you have any questions concerning your therapy.

## Symbol Key

The following symbols may appear on the device and power supply:

SYMBOL	DEFINITION
	Consult accompanying instructions for use.
	AC Power
	DC Power
<b>IP22</b>	Drip Proof Equipment
	Caution, consult accompanying documents.
	ESD Warning symbol
	Class II (Double Insulated)
	Type BF Applied Part
	For Indoor Use Only.
	Do not disassemble.
	For Airline Use. Complies with RTCA/DO-160F section 21, category M.
	Separate collection for electrical and electronic equipment per EC Directive 2002/96/EC.
	Use only with the standard 60W power supply 1091398. (not for use with Heated Tubing)
	Use only with the Heated Tubing compatible 80W power supply 1091399. (can also be used when Heated Tubing is not in use)

## System Contents

Your REMstar SE system may include the following items:

- Device
- User manual
- Carrying case
- Flexible tubing
- Power cord
- Power supply (60W [REF](#) 1091398, or 80W [REF](#) 1091399)
- Side cover panel
- SD card
- Reusable gray foam filter
- Disposable ultra-fine filter (optional)
- Humidifier (optional)

**Note:** If any of these items are missing, contact your home care provider.

## System Overview

The REMstar SE is a CPAP (Continuous Positive Airway Pressure) device designed for the treatment of Obstructive Sleep Apnea (OSA). CPAP maintains a constant level of pressure throughout the breathing cycle.

When prescribed for you, the device provides several special features to help make your therapy more comfortable. The ramp function allows you to lower the pressure when you are trying to fall asleep. The air pressure will gradually increase until your prescription pressure is reached. You also have the option of not using the ramp feature at all.

Additionally, the Flex comfort feature provides you with pressure relief when you exhale during therapy.

Several accessories are also available for use with your device. Contact your home care provider to purchase any accessories not included with your system.

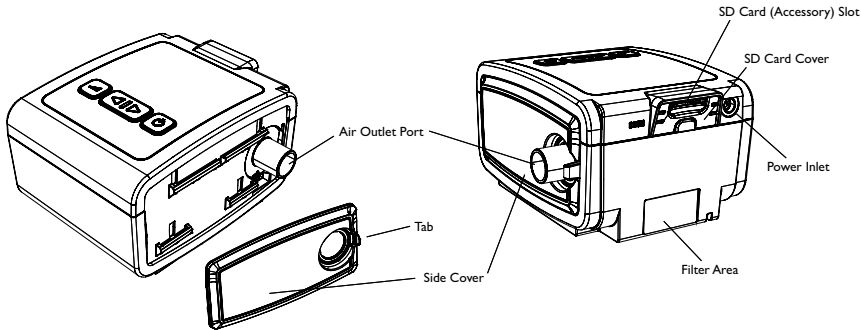

**This figure illustrates some of the device features, described in the following table.**

DEVICE FEATURE	DESCRIPTION
Air Outlet Port (conical, 22 mm)	Connect the 15 or 22 mm Philips Respironics flexible tubing here. <b>Note:</b> Heated Tubing should only be connected to the Air Outlet Port of the compatible System One Heated Humidifier and not to the Air Outlet Port of the therapy device.
SD Card (Accessory) Slot	If applicable, insert the optional accessory SD card here.
SD Card Cover	If applicable, the optional accessories such as a Link Module or Modem can be installed here. Refer to the instructions supplied with the accessory. When not using an accessory, this cover must be in place on the device.
Power Inlet	Connect the power cord here.
Filter Area	A reusable, gray foam filter must be placed in the filter area to screen out normal household dust and pollens. A white ultra-fine filter can also be used for more complete filtration of very fine particles.
Side Cover	If using a humidifier with the device, this side cover can be easily removed with the release tab before attaching the humidifier. Refer to the humidifier manual. When not using a humidifier, this cover must be in place on the device.

# Control Buttons

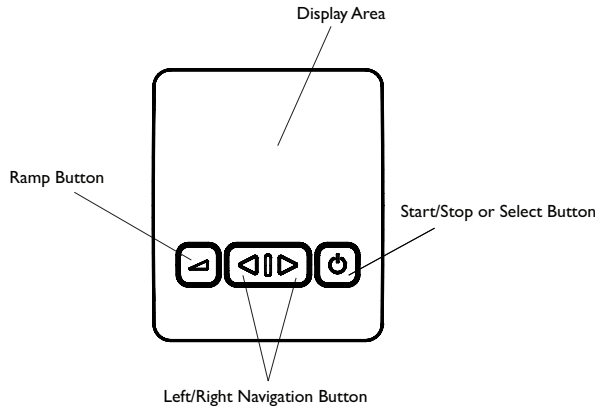

These features are described below.

FEATURE	DESCRIPTION
Display Area	This area shows the therapy settings and patient data, and other messages.
Ramp Button	When the airflow is on, this button allows you to activate or restart the ramp function. Ramp lowers the airflow pressure and then gradually increases it, allowing you to fall asleep more easily.
Start/Stop or Select Button	Starts the airflow and places the device into Active state, or stops the airflow, and places the device into Standby state. Also, when navigating the patient screens, press this button to select the menu options.
Left/Right Navigation Button	Performs display navigation or setting adjustments.

**Note:** The control buttons are backlit and will be on when the device is plugged into a power outlet.

## Available Therapies

The REMstar SE device delivers the following therapies:

- **CPAP** – Delivers Continuous Positive Airway Pressure; CPAP maintains a constant level of pressure throughout the breathing cycle.
- **CPAP with Flex** – Delivers CPAP therapy with pressure relief upon exhalation to improve patient comfort based on patient needs.

## Installing the Air Filters

**CAUTION:** A properly installed, undamaged reusable gray foam filter is required for proper operation.

The device uses a gray foam filter that is washable and reusable, and an optional white ultra-fine filter that is disposable. The reusable filter screens out normal household dust and pollens, while the optional ultra-fine filter provides more complete filtration of very fine particles. The gray reusable filter must be in place at all times when the device is operating. The ultra-fine filter is recommended for people who are sensitive to tobacco smoke or other small particles.

A reusable gray foam filter and a disposable ultra-fine filter are supplied with the device. If your filters are not already installed when you receive your device, you must at least install the reusable gray foam filter before using the device.

To install the filter(s):

1. If you are using the white disposable ultra-fine filter, insert it into the filter area first, mesh-side facing in, towards the device.
2. Insert the gray foam filter into the filter area after the ultra-fine filter.

**Note:** If you are not using the white disposable filter, simply insert the gray foam filter into the filter area.



## Connecting the Breathing Circuit

To use the system, you will need the following accessories in order to assemble the recommended circuit:

- Philips Respironics interface (nasal mask or full face mask) with integrated exhalation port, or Philips Respironics interface with a separate exhalation device (such as the Whisper Swivel II)  
**WARNING:** If you are using a full face mask (a mask covering both your mouth and your nose), the mask must be equipped with a safety (enainment) valve.
- Philips Respironics 22 mm (or 15 mm) flexible tubing, 1.83 m (6 ft.)
- Philips Respironics headgear (for the mask)

**WARNING:** If the device is used by multiple persons (such as rental devices), a low-resistance, main flow bacteria filter should be installed in-line between the device and the circuit tubing to prevent contamination.

To connect your breathing circuit to the device, complete the following steps:

1. Connect the flexible tubing to the air outlet on the side of the device.

**Note:** Make sure the Tubing type setting (15 or 22) matches the tubing you are using (Philips Respironics 15 or 22 mm tubing).

**Note:** Heated Tubing should only be connected to the Air Outlet Port of the compatible System One Heated Humidifier and not to the Air Outlet Port of the therapy device.

**Note:** If required, connect a bacteria filter to the device air outlet, and then connect the flexible tubing to the outlet of the bacteria filter.

**Note:** When using the bacteria filter, the device performance may be affected. However, the device will remain functional and deliver therapy.

2. Connect the tubing to the mask. Refer to the instructions that came with your mask.
3. Attach the headgear to the mask if necessary. Refer to the instructions that came with your headgear.

## Where to Place the Device

Place the device on a firm, flat surface somewhere within easy reach of where you will use it at a level lower than your sleeping position. Make sure the filter area on the back of the device is not blocked by bedding, curtains, or other items. Air must flow freely around the device for the system to work properly. Make sure the device is away from any heating or cooling equipment (forced air vents, radiators, air conditioners).

**CAUTION:** Do not place the device directly onto carpet, fabric, or other flammable materials.

**CAUTION:** Do not place the device in or on any container that can collect or hold water.

## Supplying AC Power to the Device

**CAUTION:** Condensation may damage the device. If this device has been exposed to either very hot or very cold temperatures, allow it to adjust to room temperature (operating temperature) before starting therapy. Do not operate the device outside of the operating temperature range shown in the Specifications.

**WARNING:** Be sure to route the power cord to the outlet in a way that will prevent the cord from being tripped over or interfered with by chairs or other furniture.

**WARNING:** This device is activated when the power cord is connected.

**IMPORTANT:** If you are using your device with a humidifier, refer to the instructions included with your humidifier for details on how to power the device and humidifier.

Complete the following steps to operate the device using AC power:

1. Plug the socket end of the AC power cord (included) into the power supply (also included).  
**IMPORTANT:** When you are using Heated Tubing with the compatible System One Heated Humidifier, you must use the 80W power supply.
2. Plug the pronged end of the AC power cord into an electrical outlet that is not controlled by a wall switch.
3. Plug the power supply cord's connector into the power inlet on the back of the device.
4. Ensure that all connections are secure.

**IMPORTANT:** To remove AC power, disconnect the power supply cord from the electrical outlet.

**WARNING:** Periodically inspect electrical cords and cables for damage or signs of wear. Discontinue use and replace if damaged.

**CAUTION:** Do not use extension cords with this device.

# Display

The display screen is shown here.

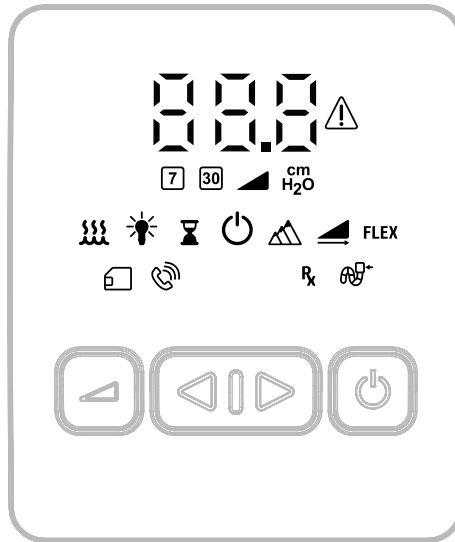

The information shown on the display is defined as follows:

ICON	DESCRIPTION	ICON	DESCRIPTION
	Device requires user attention		Therapy ON/OFF icon
	Seven day average		Altitude setting
	Thirty day average		Ramp duration setting
	Ramp starting pressure setting	<b>FLEX</b>	Flex setting
<b>cm H<sub>2</sub>O</b>	Pressure setting		SD card data activity
	Heated humidifier		Modem operation
	Backlight	<b>Rx</b>	Prescription setting
	Therapy Hours Time Meter		Tubing type setting

## Starting the Device

**Note:** The numbers shown in the screens throughout this manual are examples only. Actual numbers will vary.

1. Plug the device into an AC power source. The complete display screen will light up briefly followed by the Software Version screen for a few seconds.
2. The control buttons will then light up which indicates that the device is now in the standby state.
3. Press the START/STOP button (⏻) to turn on the airflow. Put on your mask assembly when the air starts to flow.

**Note:** There will be a short pause after pressing the START/STOP button until the air starts to flow.

4. The Monitor Pressure screen will then appear, example shown here.



### Monitor Pressure Screen

The Monitor Pressure screen shows the current pressure setting in cm H<sub>2</sub>O.

5. Make sure that no air is leaking from your mask into your eyes. If it is, adjust the mask and headgear until the air leak stops. See the instructions provided with your mask for more information.

**Note:** A small amount of mask leak is normal and acceptable. Correct large mask leaks or eye irritation from an air leak as soon as possible.

**Note:** If you are using the device in bed, try placing the tubing from the device over your headboard. This may reduce tension on the mask.

**Note:** You must remove the mask and patient circuit before you get out of bed.

6. Press the START/STOP button (⏻) again to turn off therapy.

## Ramp Feature

You can press the RAMP (↘) button during therapy to activate the Ramp feature. This feature reduces the air pressure when you are trying to fall asleep and then gradually increases (ramps) the pressure until your prescription setting is reached, allowing you to fall asleep more comfortably. You can use the RAMP button as often as you wish during the night.

**Note:** If the Ramp feature is on, the Ramp icon (↘) will display below the current pressure setting.

## Humidifier Preheat

When using a humidifier, the device can preheat the water tank for up to 30 minutes prior to starting therapy.

In order to activate the preheat mode, the device must be in the standby state and have a humidifier attached. Then press and hold down the SELECT button (⏻) for 5 seconds. The humidifier icon (💧) will illuminate and the device will now be in preheat mode.



During the 30 minute preheat, you will still be able to select other menu options. If you begin therapy during this time, preheat mode will end and the current humidity setting (0, 1, 2, 3, 4, or 5) will now take effect.

## Navigating the Patient Settings









When the device is in the standby state, press and hold either the LEFT or RIGHT button for at least 2 seconds to enter the patient settings. You can then use the LEFT/RIGHT button () to navigate the patient settings, shown here.







**Note:** You can only enter these settings when the device is in standby state.

Once you highlight the setting that you want to change, press the SELECT button (). You can then use the LEFT/RIGHT button () to adjust that setting. Press the SELECT button again to save the new setting.





These settings are described here:

ICON	NAME	DESCRIPTION
	Heated Humidifier setting	<p>If using a humidifier on your device, this setting allows you to choose the humidifier mode and the desired humidity setting.</p> <p>Once you press the SELECT button to choose this setting, the letter will blink. Use the LEFT/RIGHT button to scroll between the available humidifier modes: c, o, or h. The humidifier has 3 different modes: Classic (c), System One (o), and Heated Tube (h). The Heated Tube (h) option will only display if you are using the heated tubing with the humidifier and the 80W power supply. The humidifier icon  will change color to indicate which mode is being used. White is Classic (c), Blue is System One (o), and Orange is Heated Tube (h). This icon will also display this color during therapy when the humidifier is applying heat.</p> <p>Press the SELECT button again and the number will now blink. Use the LEFT/RIGHT button to scroll between the available humidity settings: 0 (off), 1, 2, 3, 4 or 5. Press the SELECT button again to choose the setting.</p> <p>You can also access only the humidity setting screen during therapy. Simply press the LEFT/RIGHT button during therapy and the humidity setting will display. Use the LEFT/RIGHT button to choose the new humidity setting. The screen will automatically switch back to the Monitor Pressure screen.</p>
	Backlight setting	<p>This setting allows you to choose the desired backlight setting for the device screen. Once you press the SELECT button to choose this setting, the number will blink. Use the LEFT/RIGHT button to toggle between the available settings: 0 (off), 1, 2, or 3 for variable brightness. Press the SELECT button again to choose the setting.</p>
	Therapy Hours	<p>This setting allows you to view your therapy usage in hours. Once this icon is highlighted, the device will scroll through the 3 available Therapy Hours screens: total accumulated therapy hours, the 7 day therapy average (shown with the ) icon) and the 30 day average (shown with the ) icon).</p> <p><b>Note:</b> You can also access the Enhanced Compliance Check from this setting. Refer to the “Enhanced Compliance Check” section of this manual for more information.</p>
	Therapy ON/OFF	<p>When this icon is highlighted, Press the START/STOP button () to turn the airflow on or off.</p>



ICON	NAME	DESCRIPTION
	Altitude setting	<p>This screen allows you to modify the altitude adjustment setting. Once you press the SELECT button to choose this setting, the number will blink. Use the LEFT/RIGHT button to toggle between the available settings:</p> <p>1 = less than 762 m (&lt;2500 ft.)            2 = 762 m to 1524 m (2500 to 5000 ft.)            3 = 1525 m to 2286 m (5001 to 7500 ft.)</p> <p><b>Note:</b> Elevations over 2286 m (7500 ft.) may affect the accuracy of the pressure. Press the SELECT button again to save the new setting.</p> <p><b>Warning:</b> Using this device at an incorrect altitude setting could result in airflow pressures higher or lower than the prescribed setting. Always verify the altitude setting when travelling or relocating, and adjust the system accordingly.</p>
	Ramp start pressure setting	<p>This screen allows you to modify the ramp starting pressure. Once you press the SELECT button to choose this setting, the number will blink. Use the LEFT/RIGHT button to increase or decrease the ramp starting pressure from 4.0 cm H<sub>2</sub>O to your prescription pressure in 0.5 cm H<sub>2</sub>O increments. Press the SELECT button again to save the new setting.</p> <p><b>Note:</b> The Ramp start pressure setting uses the same icon as the Ramp time setting. If “cm H<sub>2</sub>O” is highlighted below the number, you are in the Ramp start pressure setting.</p>
	Ramp time setting	<p>This screen allows you to set the ramp time. The device increases the CPAP pressure from the Ramp Starting Pressure (4 cm H<sub>2</sub>O) to the CPAP prescription pressure setting over the length of time specified here. Once you press the SELECT button to choose this setting, the number will blink. Use the LEFT/RIGHT button to set the ramp time in 5 minute increments from 0 to 45. Press the SELECT button again to save the new setting.</p> <p><b>Note:</b> If the CPAP pressure is set to 4, or this setting is set to 0, nothing will happen when you press the RAMP button.</p> <p><b>Note:</b> The Ramp time setting uses the same icon as the Ramp start pressure setting. If “cm H<sub>2</sub>O” is NOT highlighted below the number, you are in the Ramp time setting.</p>
<b>FLEX</b>	Flex setting	<p>The Flex comfort feature allows you to adjust the level of air pressure relief that you feel when you exhale during therapy.</p> <p>Once you press the SELECT button to choose this setting, the number will blink. Use the LEFT/RIGHT button to toggle between the available settings: 1, 2, or 3. The setting of “1” provides a small amount of pressure relief, with higher numbers providing additional relief. Press the SELECT button again to choose the setting. If your provider has locked this setting you will see an “L” before the number and you will not be able to change it.</p>
	Tubing type setting	<p>This setting allows you to select the correct size diameter tubing that you are using with the device. Once you press the SELECT button to choose this setting, the number will blink. Use the LEFT/RIGHT button to toggle between the available settings: You can choose either (22) for the Philips Respironics 22 mm tubing, or (15) for the Philips Respironics 15 mm tubing. When using Heated Tubing, the device will automatically change this setting to the appropriate tubing type (15h) and you will not be able to change it.</p> <p><b>Note:</b> If the Heated Tubing is removed, the device will default back to the previous tubing type setting.</p>

## Device Messages

The following icons may appear during use of this device. These icons are used to provide information regarding the status of the device and are not associated with any device settings.

ICON	NAME	DESCRIPTION/ACTION
	SD Card Icon	If an SD card is inserted in the device, the SD card icon will be displayed while usage information is being recorded to the SD card. You do not need to take any special action when this icon is displayed.  If this icon is flashing, this means that an error was encountered while writing to the SD card. Remove SD card and reinsert. If the alert continues to occur, contact your home care provider.
	Modem Icon	If a modem is attached to the device, the modem icon will be displayed while data is being transferred. You do not need to take any special action when this icon is displayed.
	Prescription Icon	If the device has been programmed with a new prescription, the prescription icon will be displayed for several seconds.  If the prescription icon is displayed along with the alert icon (shown below), this means that an error was encountered while programming the new prescription. Remove SD card and reinsert. If the alert continues to occur, contact your home care provider.
	Alert Icon	When the unit detects a system error, the alert icon is displayed. When this occurs, the blower is automatically turned off and pushbutton functions are disabled. In order to use the device, the system error needs to be resolved.  Remove the power supply cord from the device to remove power. Plug the cord back into the device's power inlet to restore power. If the alert continues to occur, contact your home care provider.

## Enhanced Compliance Check

To view the Enhanced Compliance Check screen, highlight the Therapy Hours icon  when the device is in the standby state. Then press and hold both the LEFT navigation button  and the SELECT button  for 5 seconds. The device will then display the following 5 screens. It will cycle through these screens twice before returning to the standby state.

DISPLAY	DESCRIPTION
4XX	Where XX is the 2 digit month for the start date
3XX	Where XX is the 2 digit day for the start date
2XX	Where XX is the 2 digit year for the start date
1XX	Where XX is the number of days that the device was used for longer than 4 hours
0XX	Where XX is the 2 digit check code number used by your home care provider to validate the data

**Note:** If compliance data is not available for 70% or more of the last 30 days, the device will not display the information stated above. Instead the device will display 3 dashes ( - - - ).

**Note:** Your home care provider may periodically ask you for this information.

## Troubleshooting

The table below lists some of the problems you may experience with your device or mask and possible solutions to those problems.

PROBLEM	WHY IT HAPPENED	WHAT TO DO
Nothing happens when you apply power to the device. The backlights on the buttons do not light.	There's no power at the outlet or the device is unplugged.	<p>If you are using AC power, check the outlet and verify that the device is properly plugged in. Make sure there is power available at the outlet. Make sure the AC power cord is connected correctly to the power supply and the power supply cord is securely connected to the device's power inlet. If the problem continues to occur, contact your home care provider. Return both the device and power supply to your provider, so they can determine if the problem is with the device or power supply.</p> <p>If you are using DC power, make sure your DC power cord and battery adaptor cable connections are secure. Check your battery. It may need recharged or replaced. If the problem persists, check the DC cord's fuse following the instructions supplied with your DC cord. The fuse may need to be replaced. If the problem still occurs, contact your home care provider.</p>
The airflow does not turn on.	There may be a problem with the blower.	Make sure the device is powered correctly when pressing the SELECT button (⏻) to start airflow. If the airflow does not turn on, there may be a problem with your device. Contact your home care provider for assistance.
The device's display is erratic.	The device has been dropped or mishandled, or the device is in an area with high Electromagnetic Interference (EMI) emissions.	Unplug the device. Reapply power to the device. If the problem continues, relocate the device to an area with lower EMI emissions (away from electronic equipment such as cellular phones, cordless phones, computers, TVs, electronic games, hair dryers, etc.). If the problem still occurs, contact your home care provider for assistance.
The Ramp feature does not work when you press the Ramp button.	Your CPAP pressure is already set to the minimum setting, Ramp Time setting is set to 0, or your Ramp Starting Pressure is the same as your prescribed pressure.	<p>If your CPAP is already set to the minimum setting (4.0 cm H<sub>2</sub>O), then the Ramp feature is not available. This cannot be changed.</p> <p>If your Ramp Time setting is set to zero, increase the time to anywhere between 5 and 45 minutes. Refer to "Navigating the Patient Settings" section of this manual for instructions.</p> <p>If your Ramp Starting Pressure is the same as your prescription pressure, decrease the Ramp Starting Pressure so that it is lower than your prescription pressure. To verify your prescription pressure, start the airflow on your device and note the number on the display. You can then verify and change the Ramp Starting Pressure as described in the "Navigating the Patient Settings" section of this manual.</p>
The airflow is much warmer than usual.	<p>The air filters may be dirty.</p> <p>The device may be operating in direct sunlight or near a heater.</p>	<p>Clean or replace the air filters.</p> <p>The temperature of the air may vary somewhat based on your room temperature. Make sure that the device is properly ventilated. Keep the device away from bedding or curtains that could block the flow of air around the device. Make sure the device is away from direct sunlight and heating equipment.</p> <p>If using the humidifier with the device, check the humidifier settings. Refer to the humidifier instructions to make sure the humidifier is working properly. If the problem continues, contact your home care provider.</p>

PROBLEM	WHY IT HAPPENED	WHAT TO DO
The airflow pressure feels too high or too low.	The Tubing type setting may be incorrect.	Make sure the Tubing type setting (22 or 15) matches the tubing that you are using (Philips Respironics 22 or 15 mm tubing). If you are using the Heated Tubing, this setting will be 15h and you cannot change it.
The Heated Tubing is being used and is turned on in the Heated Humidifier settings, but the Heated Tubing is not warm.	Incorrect power supply is being used (60W is used instead of 80W). Heated Tubing is attached incorrectly or damaged.	Make sure the 80W power supply is being used. This can be confirmed by looking at the power supply for the 60W or 80W symbols. Inspect Heated Tubing for damage and reconnect. If the problem continues, contact your home care provider.
The Heated Tubing is being used and is turned on in the Heated Humidifier settings, but the Humidifier LED does not stay orange (changes to blue).	Incorrect power supply is being used (60W is used instead of 80W). Heated Tubing is attached incorrectly or damaged.	Make sure the 80W power supply is being used. This can be confirmed by looking at the power supply for the 60W or 80W symbols. Inspect Heated Tubing for damage and reconnect. If the problem continues, contact your home care provider.



## Accessories

There are several accessories available for your REMstar SE system such as a humidifier or a modem. Contact your home care provider for additional information on the available accessories. When using optional accessories, always follow the instructions enclosed with the accessories.

**CAUTION:** Pins of connectors marked with the ESD warning symbol shall not be touched and connections shall not be made without special precautions. Precautionary procedures include methods to prevent build-up of electrostatic charge (e.g., air conditioning, humidification, conductive floor coverings, non-synthetic clothing), discharging one's body to the frame of the equipment or system or to earth. It is recommended that all individuals that will handle this device understand these precautionary procedures at a minimum as part of their training.

### Adding a Humidifier with or without Heated Tubing

You can use the heated humidifier and the heated tube with your device. They are available from your home care provider. A humidifier and heated tube may reduce nasal dryness and irritation by adding moisture to the airflow.

**WARNING:** For safe operation, the humidifier must always be positioned below the breathing circuit connection at the mask and the air outlet on the device. The humidifier must be level for proper operation.

**Note:** Refer to the humidifier's instructions for complete setup information.

### Using the SD Card

The REMstar SE system may come with an SD card inserted in the SD card slot on the back of the device to record information for the home care provider. Your home care provider may ask you to periodically remove the SD card and send it to them for evaluation. The SD card does not need to be installed for the device to work properly. Contact your provider if you have any questions about the SD card.

### Adding Supplemental Oxygen

Oxygen may be added at the mask connection. Please note the warnings listed below when using oxygen with the device.

#### **WARNINGS:**

- When using oxygen with this system, the oxygen supply must comply with local regulations for medical oxygen.
- Oxygen supports combustion. Oxygen should not be used while smoking or in the presence of an open flame.
- When using oxygen with this system, a Philips Respironics Pressure Valve must be placed in-line with the patient circuit between the device and the oxygen source. The pressure valve helps prevent the backflow of oxygen from the patient circuit into the device when the unit is off. Failure to use the pressure valve could result in a fire hazard.

**Note:** Refer to the pressure valve's instructions for complete setup information.

- When using oxygen with this system, turn the device on before turning on the oxygen. Turn the oxygen off before turning the device off. This will prevent oxygen accumulation in the device.
- Do not connect the device to an unregulated or high pressure oxygen source.

### Supplying DC Power to the Device

The Philips Respironics DC Power Cord can be used to operate this device in a stationary recreational vehicle, boat, or motor home. The Philips Respironics DC Battery Adapter Cable, when used with the DC Power Cord, enables the device to be operated from a 12 VDC free-standing battery.

**CAUTION:** Always ensure that the DC power cord securely fits into your therapy device prior to use.

Contact your home care provider or Philips Respironics to determine if you have the appropriate DC cord for your specific therapy device.

**CAUTION:** When DC power is obtained from a vehicle battery, the device should not be used while the vehicle's engine is running. Damage to the device may occur.

**CAUTION:** Only use a Philips Respironics DC Power Cord and Battery Adapter Cable. Use of any other system may cause damage to the device.

Refer to the instructions supplied with the DC Power Cord and adapter cable for information on how to operate the device using DC power.

## Traveling with the System

When traveling, the carrying case is for carry-on luggage only. The carrying case will not protect the system if it is put through checked baggage.

For your convenience at security stations, there is a note on the bottom of the device stating that it is medical equipment and is suitable for airline use. It may be helpful to bring this manual along with you to help security personnel understand the REMstar SE device.

If you are traveling to a country with a line voltage different than the one you are currently using, a different power cord or an international plug adaptor may be required to make your power cord compatible with the power outlets of the country to which you are traveling. Contact your home care provider for additional information.

### Airline Travel

The REMstar SE device is suitable for use on airlines when the device is operating from an AC or DC power source.

**Note:** It is not suitable for airline use with any of the modems or humidifiers installed in the unit.

## Cleaning the Device

**WARNING:** To avoid electrical shock, always unplug the power cord from the wall outlet before cleaning the device. DO NOT immerse the device in any fluids.

1. Unplug the device, and wipe the outside of the device with a cloth slightly dampened with water and a mild detergent. Let the device dry completely before plugging in the power cord.
2. Inspect the device and all circuit parts for damage after cleaning. Replace any damaged parts.

## Cleaning or Replacing the Filters

Under normal usage, you should clean the gray foam filter at least once every two weeks and replace it with a new one every six months. The white ultra-fine filter is disposable and should be replaced after 30 nights of use or sooner if it appears dirty. DO NOT clean the ultra-fine filter.

**CAUTION:** Dirty inlet filters may cause high operating temperatures that may affect device performance.

Regularly examine the inlet filters as needed for integrity and cleanliness.

1. If the device is operating, stop the airflow. Disconnect the device from the power source.
2. Remove the filter(s) from the enclosure by gently squeezing the filter in the center and pulling it away from the device.
3. Examine the filter(s) for cleanliness and integrity.
4. Wash the gray foam filter in warm water with a mild detergent. Rinse thoroughly to remove all detergent residue. Allow the filter to air dry completely before reinstalling it. If the foam filter is torn, replace it. (Only Philips Respironics-supplied filters should be used as replacement filters.)
5. If the white ultra-fine filter is dirty or torn, replace it.
6. Reinstall the filters, inserting the white ultra-fine filter first if applicable.

**CAUTION:** Never install a wet filter into the device. You must ensure sufficient drying time for the cleaned filter.

## Cleaning the Tubing

Clean the flexible tubing before first use and daily. Disconnect the flexible tubing from the device. For the 15 or 22 mm flexible tubing, gently wash the tubing in a solution of warm water and a mild detergent. Rinse thoroughly. Air dry.

**Note:** Refer to the humidifier manual for the instructions on how to clean the heated tube.

## Service

The device does not require routine servicing.

**WARNING:** If you notice any unexplained changes in the performance of this device, if it is making unusual or harsh sounds, if it has been dropped or mishandled, if water is spilled into the enclosure, or if the enclosure is broken, disconnect the power cord and discontinue use. Contact your home care provider.

# Specifications

## Environmental

Operating Temperature: 5° to 35° C (41° to 95° F)

Storage Temperature: -20° to 60° C (-4° to 140° F)

Relative Humidity (operating & storage): 15 to 95% (non-condensing)

Atmospheric Pressure: 101 to 77 kPa (0 - 2286 m / 0 - 7500 ft)

## Physical

Dimensions: 18 x 14 x 10 cm (7" L x 5.5" W x 4" H)

Weight (Device with power supply): Approximately 1.53 kg (3.37 lbs)

## Standards Compliance

This device is designed to conform to the following standards:

IEC 60601-1 General Requirements for Safety of Medical Electrical Equipment

EN ISO 17510-1 Sleep Apnea Breathing Therapy Devices

EN 60601-1-2 Electromagnetic Compatibility

RTCA/DO-160F section 21, category M; Emission of Radio Frequency Energy

## IEC 60601-1 Classification

Type of Protection Against Electric Shock: Class II Equipment

Degree of Protection Against Electric Shock: Type BF Applied Part

Degree of Protection against Ingress of Water:

Device: Drip Proof, IP22

60W power supply: Drip Proof, IP22

80W power supply: Drip Proof, IP22

Mode of Operation: Continuous

## Electrical

AC Power Consumption (with 60W power supply): 100 – 240 VAC, 50/60 Hz, 2.1 A

AC Power Consumption (with 80W power supply): 100 – 240 VAC, 50/60 Hz, 2.0 A

DC Power Consumption: 12 VDC, 6.67 A

Fuses: There are no user-replaceable fuses.

## Declared Dual-Number Noise Emissions Values

In accordance with ISO 4871

The measured A-weighted emission sound pressure level is 29.3 dB(A) with an uncertainty of 1.6 dB(A).

The measured A-weighted sound power level is 37.3 dB(A) with an uncertainty of 1.6 dB(A).

### Notes:

- These measurements apply to this device with an optional humidifier. Use of this device without a humidifier would result in measurements equal to or less than the stated values.
- Values determined according to noise test code given in ISO 17510-1:2007, using the basic standards ISO 3744 and ISO 4871.

## Pressure Accuracy

Pressure Increments: 4.0 to 20.0 cm H<sub>2</sub>O (in 0.5 cm H<sub>2</sub>O increments)

Pressure Stability:

	Static	Dynamic < 10 cm H <sub>2</sub> O	Dynamic ≥ 10.0 to 20 cm H <sub>2</sub> O
<b>Device</b>	± 1.0 cm H <sub>2</sub> O	≤ 2.0 cm H <sub>2</sub> O	≤ 2.0 cm H <sub>2</sub> O
<b>Device w/ Humidifier</b> (22 mm tubing)	± 1.0 cm H <sub>2</sub> O	≤ 2.0 cm H <sub>2</sub> O	≤ 2.0 cm H <sub>2</sub> O
<b>Device w/ Humidifier</b> (15 mm tubing)	± 1.0 cm H <sub>2</sub> O	≤ 2.0 cm H <sub>2</sub> O	≤ 2.5 cm H <sub>2</sub> O

## Maximum Flow Rate (typical)

		Test pressures (cm H <sub>2</sub> O)				
		4.0	8.0	12.0	16.0	20.0
<b>22 mm tubing</b>	<b>Measured pressure at the patient connection port (cm H<sub>2</sub>O)</b>	3.0	7.0	11.0	15.0	19.0
	<b>Average flow at the patient connection port (l/min)</b>	33.2	36.8	41.0	45.6	48.1
<b>15 mm tubing</b> (heated or non-heated)	<b>Measured pressure at the patient connection port (cm H<sub>2</sub>O)</b>	3.0	7.0	11.0	15.0	19.0
	<b>Average flow at the patient connection port (l/min)</b>	27.8	31.1	35.0	37.9	41.4

## Disposal

Separate collection for electrical and electronic equipment per EC Directive 2002/96/EC. Dispose of this device in accordance with local regulations.

## How to Contact Philips Respironics

To have your device serviced, contact your home care provider. If you need to contact Philips Respironics directly, call the Philips Respironics Customer Service department at 1-800-345-6443 or 1-724-387-4000. You can also use the following address:

Respironics, Inc.  
1001 Murry Ridge Lane  
Murrysville, PA 15668

## EMC Information

Guidance and Manufacturer's Declaration - Electromagnetic Emissions – This device is intended for use in the electromagnetic environment specified below. The user of this device should make sure it is used in such an environment.

EMISSIONS TEST	COMPLIANCE	ELECTROMAGNETIC ENVIRONMENT - GUIDANCE
RF emissions CISPR 11	Group 1	The device uses RF energy only for its internal function. Therefore, its RF emissions are very low and are not likely to cause any interference in nearby electronic equipment.
RF emissions CISPR 11	Class B	The device is suitable for use in all establishments, including domestic establishments and those directly connected to the public low-voltage power supply network.
Harmonic emissions IEC 61000-3-2	Class A	
Voltage fluctuations/Flicker emissions IEC 61000-3-3	Complies	

Guidance and Manufacturer's Declaration - Electromagnetic Immunity – This device is intended for use in the electromagnetic environment specified below. The user of this device should make sure it is used in such an environment.

IMMUNITY TEST	IEC 60601 TEST LEVEL	COMPLIANCE LEVEL	ELECTROMAGNETIC ENVIRONMENT - GUIDANCE
Electrostatic Discharge (ESD) IEC 61000-4-2	±6 kV contact ±8 kV air	±6 kV contact ±8 kV air	Floors should be wood, concrete or ceramic tile. If floors are covered with synthetic material, the relative humidity should be at least 30%.
Electrical fast Transient/burst IEC 61000-4-4	±2 kV for power supply lines ±1 kV for input-output lines	±2 kV for supply mains ±1 kV for input/output lines	Mains power quality should be that of a typical home or hospital environment.
Surge IEC 61000-4-5	±1 kV differential mode ±2 kV common mode	±1 kV differential mode ±2 kV for common mode	Mains power quality should be that of a typical home or hospital environment.
Voltage dips, short interruptions and voltage variations on power supply input lines IEC 61000-4-11	<5% $U_T$ (>95% dip in $U_T$ ) for 0.5 cycle 40% $U_T$ (60% dip in $U_T$ ) for 5 cycles 70% $U_T$ (30% dip in $U_T$ ) for 25 cycles <5% $U_T$ (>95% dip in $U_T$ ) for 5 sec	<5% $U_T$ (>95% dip in $U_T$ ) for 0.5 cycle 40% $U_T$ (60% dip in $U_T$ ) for 5 cycles 70% $U_T$ (30% dip in $U_T$ ) for 25 cycles <5% $U_T$ (>95% dip in $U_T$ ) for 5 sec	Mains power quality should be that of a typical home or hospital environment. If the user of the device requires continued operation during power mains interruptions, it is recommended that the device be powered from an uninterruptible power supply or a battery.
Power frequency (50/60 Hz) magnetic field IEC 61000-4-8	3 A/m	3 A/m	Power frequency magnetic fields should be at levels characteristic of a typical location in a typical hospital or home environment.
NOTE: $U_T$ is the a.c. mains voltage prior to application of the test level.			

Guidance and Manufacturer's Declaration - Electromagnetic Immunity – This device is intended for use in the electromagnetic environment specified below. The user of this device should make sure it is used in such an environment.

IMMUNITY TEST	IEC 60601 TEST LEVEL	COMPLIANCE LEVEL	ELECTROMAGNETIC ENVIRONMENT -GUIDANCE
Conducted RF IEC 61000-4-6	3 Vrms 150 kHz to 80 MHz	3 Vrms	<p>Portable and mobile RF communications equipment should be used no closer to any part of the device, including cables, than the recommended separation distance calculated from the equation applicable to the frequency of the transmitter.</p> <p>Recommended separation distance  <math>d = 1.2 \sqrt{P}</math></p> <p><math>d = 1.2 \sqrt{P}</math>      80 MHz to 800 MHz  <math>d = 2.3 \sqrt{P}</math>      800 MHz to 2.5 GHz</p> <p>where P is the maximum output power rating of the transmitter in watts (W) according to the transmitter manufacturer and d is the recommended separation distance in meters (m).</p> <p>Field strengths from fixed RF transmitters, as determined by an electromagnetic site survey<sup>a</sup>, should be less than the compliance level in each frequency range.<sup>b</sup></p> <p>Interference may occur in the vicinity of equipment marked with the following symbol: </p>
Radiated RF IEC 61000-4-3	3 V/m 80 MHz to 2.5 GHz	3 V/m	

NOTE 1 At 80 MHz and 800 MHz, the higher frequency range applies.  
 NOTE 2 These guidelines may not apply in all situations. Electromagnetic propagation is affected by absorption and reflection from structures, objects, and people.

a Field strengths from fixed transmitters, such as base stations for radio (cellular/cordless) telephones and land mobile radios, amateur radio, AM and FM radio broadcast and TV broadcast cannot be predicted theoretically with accuracy. To assess the electromagnetic environment due to fixed RF transmitters, an electromagnetic site survey should be considered. If the measured field strength in the location in which the device is used exceeds the applicable RF compliance level above, the device should be observed to verify normal operation. If abnormal performance is observed, additional measures may be necessary, such as re-orienting or relocating the device.

b Over the frequency range 150 kHz to 80 MHz, the field strengths should be less than 3 V/m.

Recommended Separation Distances between Portable and Mobile RF Communications Equipment and This Device: The device is intended for use in an electromagnetic environment in which radiated RF disturbances are controlled. The customer or the user of this device can help prevent electromagnetic interference by maintaining a minimum distance between portable and mobile RF communications equipment (transmitters) and this device as recommended below, according to the maximum output power of the communications equipment.

RATED MAXIMUM POWER OUTPUT OF TRANSMITTER W	SEPARATION DISTANCE ACCORDING TO FREQUENCY OF TRANSMITTER M		
	150 kHz TO 80 MHz $d = 1.2 \sqrt{P}$	80 MHz TO 800 MHz $d = 1.2 \sqrt{P}$	800 MHz TO 2.5 GHz $d = 2.3 \sqrt{P}$
0.01	0.12	0.12	0.23
0.1	0.38	0.38	0.73
1	1.2	1.2	2.3
10	3.8	3.8	7.3
100	12	12	23

For transmitters rated at a maximum output power not listed above, the recommended separation distance d in meters (m) can be estimated using the equation applicable to the frequency of the transmitter, where P is the maximum output power rating of the transmitter in watts (W) according to the transmitter manufacturer.

Note 1: At 80 MHz and 800 MHz, the separation distance for the higher frequency range applies.  
 Note 2: These guidelines may not apply in all situations. Electromagnetic propagation is affected by absorption and reflection from structures, objects, and people.

## Limited Warranty

Respironics, Inc. warrants that the system shall be free from defects of workmanship and materials and will perform in accordance with the product specifications for a period of two (2) years from the date of sale by Respironics, Inc. to the dealer. If the product fails to perform in accordance with the product specifications, Respironics, Inc. will repair or replace – at its option – the defective material or part. Respironics, Inc. will pay customary freight charges from Respironics, Inc. to the dealer location only. This warranty does not cover damage caused by accident, misuse, abuse, alteration, water ingress, and other defects not related to material or workmanship. The Respironics, Inc. Service department shall examine any devices returned for service, and Respironics, Inc. reserves the right to charge an evaluation fee for any returned device as to which no problem is found after investigation by Respironics, Inc. Service.

This warranty is non-transferable by unauthorized distributors of Respironics, Inc. products and reserves the right to charge dealers for warranty service of failed product not purchased directly from Respironics, Inc. or authorized distributors.

Respironics, Inc. disclaims all liability for economic loss, loss of profits, overhead, or consequential damages which may be claimed to arise from any sale or use of this product. Some states do not allow the exclusion or limitation of incidental or consequential damages, so the above limitation or exclusion may not apply to you.

This warranty is given in lieu of all other express warranties. In addition, any implied warranties – including any warranty of merchantability or fitness for the particular purpose – are limited to two years. Some states do not allow limitations on how long an implied warranty lasts, so the above limitation may not apply to you. This warranty gives you specific legal rights, and you may also have other rights which vary from state to state.

To exercise your rights under this warranty, contact your local authorized Respironics, Inc. dealer or contact Respironics, Inc. at:

1001 Murry Ridge Lane  
Murrysville, Pennsylvania 15668-8550  
1-724-387-4000

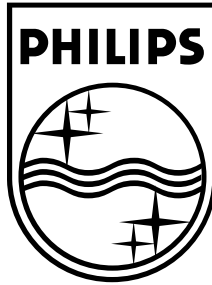

Respironics Inc.  
1001 Murry Ridge Lane  
Murrysville, PA 15668 USA



**REF 1096462**

1096314 R02  
JR 3/28/2012  
EN-DOM